



APPROVED

ROTAX MAX Challenge Technical Regulations 2003

(Version 03.03.2003)

1. Categories:

Karts used in the **ROTAX MAX CHALLENGE(RMC)**, **ROTAX MAX CHALLENGE GRAND FINAL(RMCGF)** and **ROTAX MAX CHALLENGE EVENTS (RMCE)** are divided into the following groups:

- ROTAX FR 125 Mini MAX, cyl. Capacity 125 cc
- ROTAX FR 125 Junior MAX, cyl. Capacity 125 cc
- ROTAX FR 125 MAX, cyl. Capacity 125 cc
- ROTAX 125 MAX DD2, cyl. Capacity 125 cc, 2-speed

2. Kart:

2.1. Chassis:

Any chassis sanctioned by an authorized ROTAX distributor, for 125 MAX DD2 the chassis must be built according to CIK-FIA 2003 regulations and sanctioned by Bombardier Rotax.

Max diameter for chassis tubing 32,0 mm. Round tubing only.

Rear axle diameter maximum 50,0 mm, wall thickness according to CIK-FIA rules

At the RMC Grand finals only chassis are allowed which are built according to CIK rules .

No front brakes allowed (except category 125 MAX DD2)

2.2. Bodywork:

In accordance with regulations of national Federation or CIK-FIA.

At the RMCGF only bodywork is allowed which is homologated according to CIK-FIA homologation regulations.

For category 125 MAX DD2 only CIK-FIA 2003 homologated bodywork is allowed. Additionally the ROTAX rear fender system (with integrated rear tyre protection) must be used.

2.3. Tyres:

The only tires allowed in races of a national or regional RMC are:

Slick tires: Bridgestone	Type: YGK	
	Front: 4.5 x 10.0 -5	Rear: 7.1 x 11.0 –5

Wet tires: Bridgestone	Type: YGR	
	Front: 4.0 x 10.0 -5	Rear: 6.0 x 11.0 –5

Strictly no modifications or tire treatment allowed.

2.4. Composite materials:

Composite materials (carbonfibre etc) are banned, except for the seat.

2.5. Petrol:

Unleaded commercial quality from petrol station, max. 98 octane

2.6. Amount of equipment:

For each race event: max. 1 chassis, max. 2 engines, 1 set of slick tires, 1 set of as well as 1 front and 1 rear spare tire are allowed.

Material used in qualifying must be used at the races (exemption: tires).

2.7. Data acquisition:

Data acquisition devices for recording and displaying of data limited to engine rpm, maximum rpm, coolant temperature, lap times and engine hours.

3. Safety of equipment:

For RMCGF and RMCE article 3 of CIK-FIA technical regulations apply.

For RMC overalls , helmets, kart shoes, gloves and other kind of driver protection must comply with regulation of ASN in which RMC is organized.

4. Engines

At all RMC, RMCGF and RMCE races only Rotax kart engines which have been checked according to the procedure below are legal to be used:

Each engine is delivered with its own engine passport.

Only “Authorized ROTAX Distributors” and “Authorized ROTAX Service Centers” are allowed to seal engines after carefully checking the engine according to the „Technical Specification

for the ROTAX FR 125 MAX“ / “Technical Specification of ROTAX engine type 125 MAX DD2” engine (see item 4.1 and 4.2)

Special ROTAX seals (black anodized aluminium seal with „ROTAX“ logo and a 6 digit number) with a steel cable must be used.

At scrutineering the driver has to present the engine with undamaged seal and the engine passport, showing the matching engine serial number, seal number, stamp and signature of the company which sealed the engine.

This procedure helps to reduce scrutineering times at races. Nevertheless it is possible to open and recheck the engines by scrutineers before or after the race in case of a protest and reseal the engine after checking it step by step by staff of the “Authorised ROTAX Service Center or Distributor” according to the „Technical Specification“.

4.1.1. Technical specification for Rotax kart engines :

FR 125 Max (config. no.: 371251301 / configuration 21 kW)

FR 125 Junior Max (config. no.: 300125130 / configuration 15 kW)

FR 125 Mini Max (config. no.: 300125130 / configuration 10 kW)

		ITEM	CHECKED
SQUISH GAP:	FR 125 MAX: 0,90 mm – 1,50 mm	1.1	
	FR 125 Junior MAX and FR 125 Mini MAX 1,20 mm – 1,80 mm	1.2	
COMBUSTION CHAMBER INSERT:	Identification code has to be 223 389 (4).	2.1	
	Name ROTAX has to be cast (5).	2.2	
	Height of combustion chamber insert has to be 27,55 mm with a tolerance of +0,0/-0,1 mm (6), see illustration 1.	2.3	
	The profile of the combustion chamber insert has to be checked with the combustion chamber insert template (ROTAX part no. 277 390). The crack of light between the template and the profile of the combustion chamber insert has to be the same over the whole profile.	2.4	
PISTON:	Original, coated or uncoated, aluminum, cast piston only with one, original, magnetic, 1mm-rectangular-piston ring, with 'E CRY K' marked on the ring. The piston has to show on the inside the words 'ELKO' and 'MADE IN AUSTRIA' in casting.”	3.1	
	Machined areas are: Top end of piston, outside diameter, groove for the piston ring, bore for	3.2	

	piston pin, inside diameter at bottom end of piston. All other surfaces are not machined and have cast surface.		
--	---	--	--

GUDGEON PIN	Gudgeon pin has to be made out of magnetic steel. Must be as per illustration 4.1	4.1	
CYLINDER:	<p>Light-alloy-cylinder with GILNISIL-plating, configuration with one main exhaust port and pneumatic adjusted exhaust valve (exhaust valve for configuration FR 125 MAX only) Any re-plating is not allowed.</p> <p>Maximum bore: 54,035 mm (measured 10 mm above the exhaust port).</p> <p>Cylinder has to be marked with ROTAX-Logo (1), see illustration 2.</p> <p>FR 125 MAX: Cylinder has to be marked with identification code. 223 997 (2), see illustration 2.</p> <p>FR 125 Junior MAX and FR 125 Mini MAX: Cylinder has to be marked with identification code. 223 999 (2), see illustration 2.</p> <p>Height of cylinder has to be 87 mm with a tolerance of $-0,05/+0,1$ mm (3), see illustration 3.</p> <p>All ports and passages are cast finish except some pre-existing, factory removal of flashing from inlet and exhaust port and passages. All ports have chamfered edges to prevent ring snagging. Any additional machining is not permitted.”</p>	<p>5.1</p> <p>5.2</p> <p>5.3</p> <p>5.4</p> <p>5.4</p> <p>5.5</p> <p>5.6</p>	
EXHAUST POWERVALVE	Configuration FR 125 MAX only! As supplied by the manufacturer with no modifications allowed. Compression spring must be fitted.	7.1	
CRANKSHAFT:	<p>Stroke: 54,5mm \pm 0,1 mm</p> <p>Con rod (7) has to show forged number "213" or "365" on shaft (see ill. no. 4)</p> <p>Shaft of con rod is not machined (copper plated). Grinding or polishing of shaft of con rod is not permitted.</p>	<p>8.1</p> <p>8.2</p> <p>8.3</p>	

BALANCE SHAFT	Balance shaft must be installed and operational.	9.1	
	Different configurations of part no. 237 945 and 237 949 are legal (see ill. no. 4.2)	9.2	
	Surface (1) is not machined and must be cast surface (see ill. no. 4.2).	9.3	
	Measurement from centre of balance shaft to outer diameter of fly weight of balance shaft at a defined length must not be lower than specified (see ill. no. 4.2).	9.4	
	The minimum weight of the dry balance shaft must not be lower than 355 grams for balance shaft ROTAX part no. 237 945 and 255 grams for balance shaft ROTAX part no. 237 949	9.5	
CRANKCASE	As supplied by the manufacturer. No grinding/polishing is permitted in the two main transfer passages.	10.1	
IGNITION UNIT:	DENSO digital battery ignition, variable ignition timing, no adjustment necessary and possible. Race officials may request at any time that the competitor replace the ignition coil with a new unit, provided by race administration.	11.1	
	The casing of the ignition coil has to show following castings "129000 -" and "DENSO". The ignition coil must show 3 pins at the terminal.	11.2	
	The ignition coil has to be fixed by means of two original silent blocks to the gearbox cover. Only in cases of chassis component interference with the original mounting location of the ignition coil, a supplemental extension bracket, rigidly constructed and fabricated of solid metal, of minimum dimensions and attached to the original case mounting holes, is permitted for mounting of the coil.	11.3	
	Spark plug: DENSO Iridium IW... or NGK BR ... EG	11.4	
	Original battery must be used, FIAMM-GS type FG 20651 or FG 20722 or FGHL 20722 (as soon as available from ROTAX	11.5	

	Spark plug cap must be marked with "NGK TB05EMA".	11.6	
CARBURETOR:	DELL'ORTO carburettor	12.1	
	"VHSB 34" cast in the housing of the carburettor.	12.2	
	"QD" stamped in the housing of the carburettor.	12.3	
	The complete inlet bore in the casing of the carburettor must show cast surface	12.4	
	Needle jet stamped with "FN 266"	12.5	
	The carburettor slide must show with size "40" in casting and the bottom end of the slide must show cast surface.	12.6	
	Jet needle stamped with "K27"	12.7	
	Floats are marked with "gr 5.2"	12.8	
	Idle jet is stamped with the digits "30"	12.9	
	Idle jet insert is stamped with the digits "30"	12.10	
	Start jet is stamped with the digits "60"	12.11	
	Settings of the carburetor adjustment screws are free.	12.12	
	Main jets smaller than size 160 or bigger than 200 are not recommended by ROTA	12.13	
	Main jets smaller than size 160 and bigger than size 200 are legal also if they are not available from ROTAX.	12.14	
FUEL PUMP:	MIKUNI diaphragm pump, must be placed on bottom of support bracket for intake silencer	13.1	
FUEL FILTER:	The original fuel filter (ROTAX part no. 274 160) only is allowed to be fitted between the fuel tank and the fuel pump. Any non original in line fuel filter has to be fitted between the fuel pump and the carburettor.	13.2	

RADIATOR:	Single aluminium radiator as shown in illustration 5.	14.1	
	Cooling area: Height = 290 mm, width = 133 mm	14.2	
	Thickness of radiator = 32 mm	14.3	
	Place of fixing the radiator is on right side of engine.	14.4	
	Radiator must be mounted with support bracket (5) and supporting rod (9), see illustration 5	14.5	
	No additional cooling device is allowed. Tape applied to the face of the radiator only is allowed as an air flow control means. All other means of air flow control through the radiator are prohibited.	14.6	
	New radiator mounting which will be introduced together with integrated thermostat is legal from the date on it is available from ROTAX	14.7	
RADIATOR COOLANT	As glycol coolants are not permitted, distilled water without any additives has to be used.	15.1	
CLUTCH:	Dry centrifugal clutch, engagement r.p.m. maximum at 3.000 r.p.m. That means, that the kart (without driver) must start to move latest at an engine speed of maximum 3.000 r.p.m.	16.1	
INTAKE SILENCER:	Intake silencer with integrated, washable air cleaner with all parts as shown at illustration 6, mounted on the support bracket.	17.1	
	If the race is declared a "wet race" the position and bracing of the intake silencer is free .	17.2	
	Air filter must be installed as shown in illustration 6.	17.3	
EXHAUST SYSTEM:	Must be as supplied by ROTAX and cannot be modified except for the replacement of the silencer absorption material and the use of threaded fasteners in place of the rivets for securing the silencer end cap.	18.1	
	Standard exhaust socket must be used.	18.2	

	<p>Exhaust pipe with after muffler as shown in illustration 7:</p> <p>length of inlet cone: 592 mm \pm5 mm (measured on outside from beginning of exhaust pipe until beginning of cylindrical part).</p> <p>length of cylindrical part of exhaust pipe: 125 mm \pm5 mm.</p> <p>length of end cone: 225 mm, \pm5 mm (measurement, see illustration 8).</p> <p>outside diameter of 180° bent tube: 41mm +1,5 mm/-1,0 mm (measured at beginning and end of bend).</p> <p>Diameter of hole of end cap of (illustration 7, pos. 3 or 6): 21 mm +/- 0,2 mm.</p> <p>The expansion chamber and silencer supplied with the engine may not be modified, except for the addition of extra elements to further reduce noise levels.</p>	<p>18.3</p> <p>18.4</p> <p>18.5</p> <p>18.6</p> <p>18.7</p> <p>18.8</p> <p>18.9</p>	
NOISE EMISSIONS:	<p>Noise isolating mat (illustration 7, pos. 3) has to be replaced by a original ROTAX spare part, if the noise emission is exceeding 92 dB (A).</p> <p>Noise emission measuring procedure:</p> <ul style="list-style-type: none"> • The measuring place has to be at section of the track where the engine is operated under full load and at a rpm range of 11.000 to 12.000 rpm. • The microphone has to be installed 1 meter above the level of the track in a rectangular angle to the track. • The distance between the microphone and the kart on the ideal line on the track has to be 7,5 meters. • The kart has to be operated under full load at the ideal line on the track. 	19.1	
RESTRICTORS:	<p>For engine configuration FR 125 Mini MAX (10 kW) only! No modification of restrictors allowed!</p> <p>Intake restrictor - Insert for carburettor flange with intake-diameter 19,0 +0,0/-0,2 mm.</p> <p>Exhaust restrictor – Exhaust socket with outlet-diameter 22,0 +0,0/-0,2 mm</p>	<p>20.1</p> <p>20.2</p>	

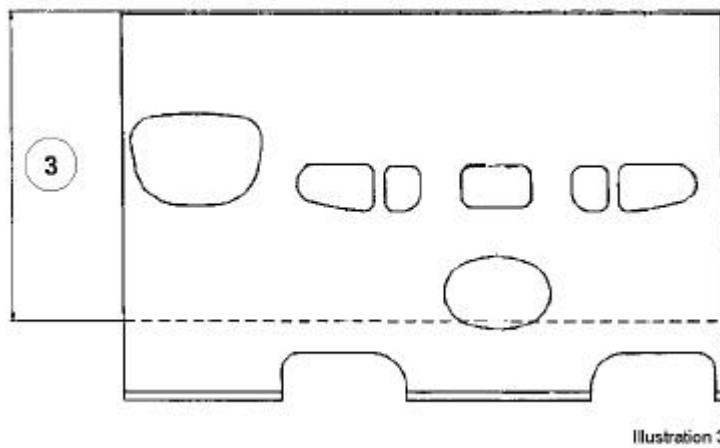
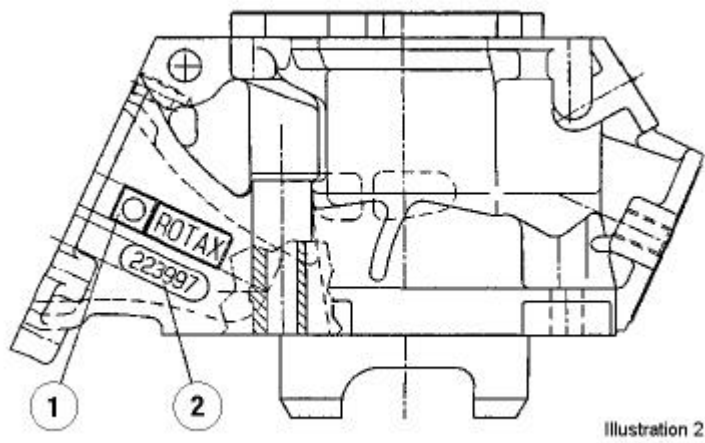
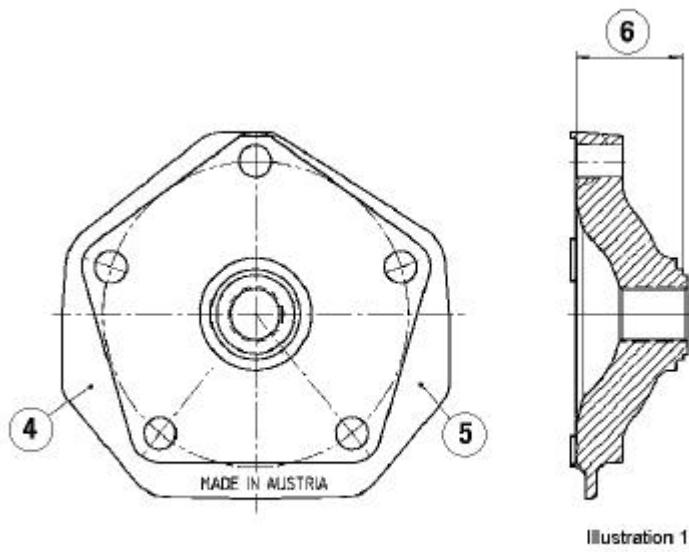

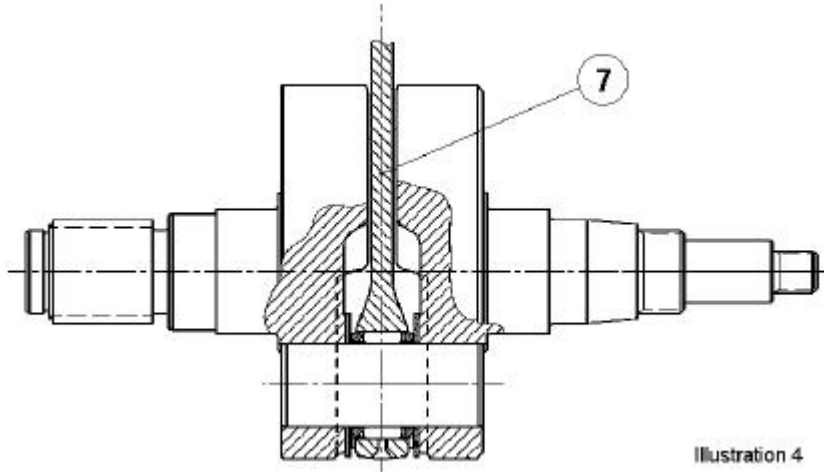

Illustration 4

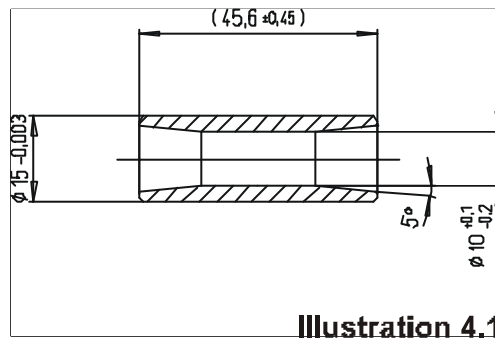
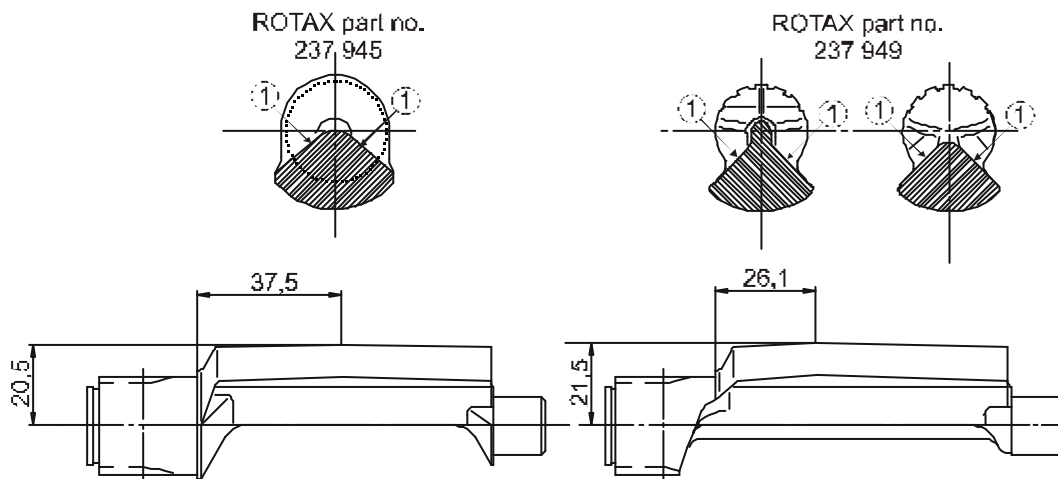
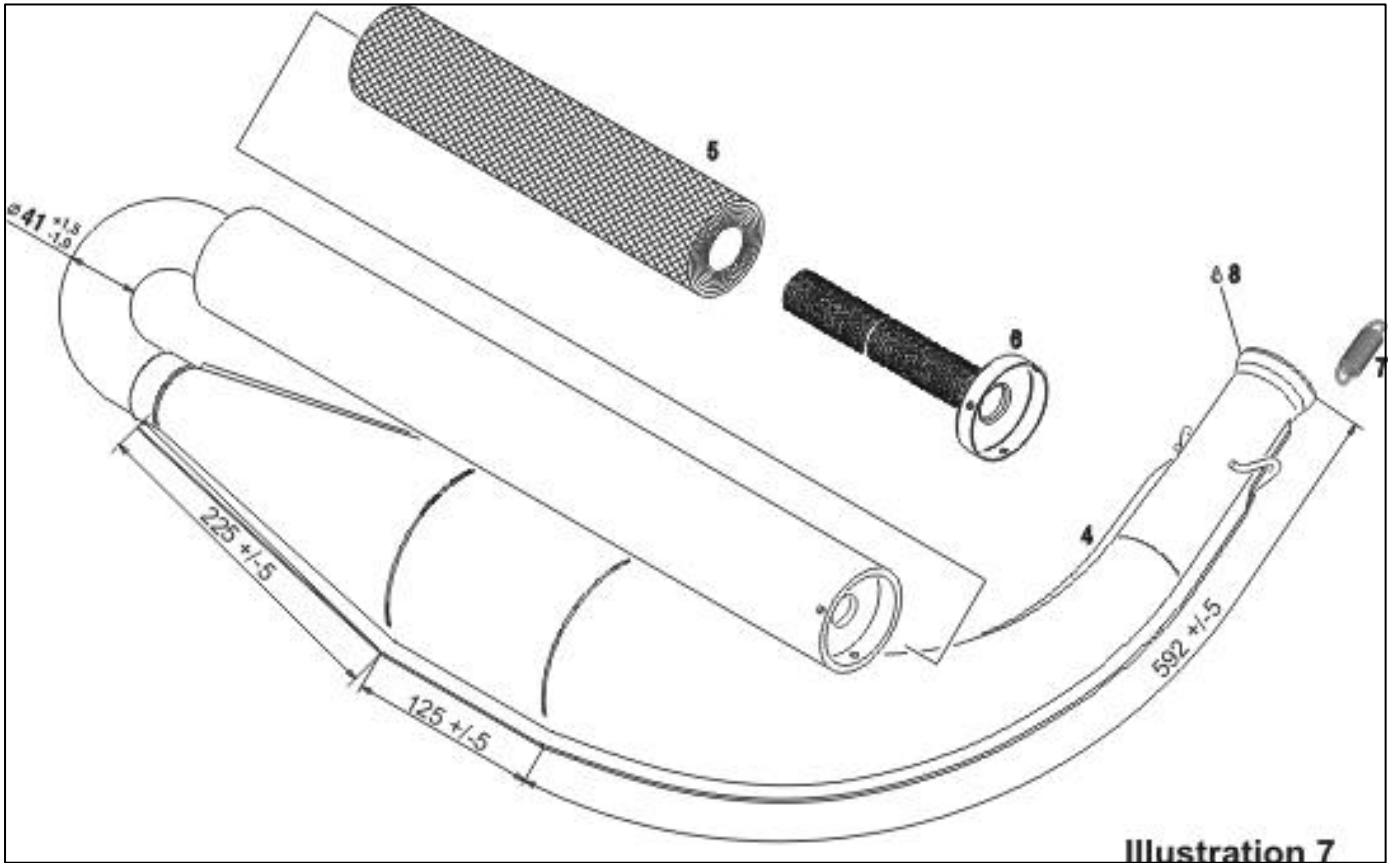

Illustration 4.1





**4.1.2. Technical specification for Rotax kart engines :
125 Max DD2 (config. no.: 330125100 / configuration 24 kW)**

This technical specification should enable the technical commission to verify the original condition of the ROTAX engine type 125 MAX DD2 with configuration 24 kW. By checking these figures step by step the uniformity of the technical basis of the engine can be confirmed. It is up to the organiser of the competition which items are used for the respective reglement.

Only genuine ROTAX components that are specifically designed and supplied for the 125 MAX DD2 engine are legal, unless otherwise specified.

Neither the engine nor any of its ancillaries may be modified in any way. "Modified" is defined as any change in form, content or function that represents a condition of difference from that originally designed. This is to include the addition and/or omission of parts and/or material from the engine package assembly unless specifically allowed within these rules. The adjustment of elements specifically designed for that purpose shall not be classified as modifications, i.e. carburetor and exhaust adjustment screws.

Internal additions: no additional material may be added except in the case of engine repairs and shall only restore the engine or components to original specifications.

- The use of thermal barrier coatings/ceramic coatings on or in the engine and on or in the exhaust system is prohibited.
- The use of anti-friction coatings in or on the engine/engine components is prohibited.

Legal additions: Temperature gauge and tachometer/hour meter, inline fuel filter and catch can, mounting brackets within the limits specified in this document.

“Non-tech items: non-original fasteners, circlips, washers, throttle cable housing, fuel and pulse line (type and size), and battery mounting bracket are allowed unless otherwise specified.”

		ITEM	CHECKED
SQUISH GAP:	0,90 mm – 1,30 mm	1.1	
COMBUSTION CHAMBER INSERT:	Identification code has to be 223 389 (4).	2.1	
	Name ROTAX has to be cast (5).	2.2	
	Height of combustion chamber insert has to be	2.3	

	<p>27,55 mm with a tolerance of +0,0/-0,1 mm (6), see illustration 1.</p> <p>The profile of the combustion chamber insert has to be checked with the combustion chamber insert template (ROTAX part no. 277 390). The crack of light between the template and the profile of the combustion chamber insert has to be the same over the whole profile.</p>	2.4	
PISTON:	<p>Original, coated or uncoated, aluminum, cast piston only with one, original, magnetic, 1mm-rectangular-piston ring, with 'E CRY K' marked on the ring. The piston has to show on the inside the words 'ELKO' and 'MADE IN AUSTRIA' in casting."</p> <p>Machined areas are: Top end of piston, outside diameter, groove for the piston ring, bore for piston pin, inside diameter at bottom end of piston. All other surfaces are not machined and have cast surface.</p>	3.1 3.2	
GUDGEON PIN	<p>Gudgeon pin has to be made out of magnetic steel. Must be as per illustration 4.1</p>	4.1	
CYLINDER:	<p>Light-alloy-cylinder with GILNISIL-plating, configuration with one main exhaust port, two side exhaust ports and pneumatic adjusted exhaust valve. Any re-plating is not allowed.</p> <p>Maximum bore: 54,035 mm (measured 10 mm above the exhaust port).</p> <p>Cylinder has to be marked with ROTAX-Logo (1), see illustration 2.</p> <p>Cylinder has to be marked with identification code. 613 930 (2), see illustration 2.</p> <p>Height of cylinder has to be 86,7 mm with a tolerance of -0,05/+0,1 mm (3)</p> <p>All ports and passages are cast finish except some pre-existing, factory removal of flashing from inlet and exhaust port and passages. All ports have chamfered edges to prevent ring snagging. Any additional machining is not permitted.</p>	5.1 5.2 5.3 5.4 5.5 5.6	
INLET SYSTEM:	<p>Intake manifold is marked with the name</p>	6.1	

	<p>ROTAX and the identification code 267 410. Some factory flash removal may be present at the junction of the inside contour and the carburetor stop mounting face. This is a manual trimming operation consisting of a small corner break of less than 1mm in width. No additional grinding or machining is permitted.</p> <p>The reed valve assy is equipped with 2 petal stops and 2 reeds, each having 3 petals.</p> <p>The thickness of the reeds is 0,6 mm, \pm 0,08 mm.</p>	6.2	
		6.3	
EXHAUST VALVE	As supplied by the manufacturer with no modifications allowed. Compression spring must be fitted.	7.1	
CRANKSHAFT:	Stroke: 54,5mm \pm 0,1 mm	8.1	
	Con rod (7) has to show forged number " 365" on shaft.	8.2	
	Shaft of con rod is not machined (copper plated). Grinding or polishing of shaft of con rod is not permitted.	8.3	
BALANCE DRIVE	Balance drive gear must be fitted on crankshaft.	9.1	
	Balance gear must be fitted on primary shaft.	9.2	
	Surface of flyweight on balance gear must not show any machining.	9.3	
2-SPEED GEARBOX	Primary shaft with 19 teeth for 1 st gear and 24 teeth for 2 nd gear.	10.1	
	The idle gear for 1 st gear has to have 81 teeth.	10.2	
	The idle gear for 2 nd gear has to have 77 teeth.	10.3	
	The gears have to be operated by the original shift paddle on the steering wheel via the two cable bowden	10.4	
CRANKCASE	As supplied by the manufacturer. The two transfer passages are cast finish except some pre-existing, factory removal of flashing. No additional grinding/polishing is permitted in	11.1	

	the two main transfer passages.		
IGNITION UNIT:	DENSO digital battery ignition, variable ignition timing, no adjustment necessary and possible. Race officials may request at any time that the competitor replace the ignition coil with a new unit, provided by race administration.	12.1	
	The casing of the ignition coil has to show following castings "129000 -" and "DENSO". The ignition coil must show 6 pins at the terminal.	12.2	
	The ignition coil has to be fixed by means of two original silent blocks to the crankcase.	12.3	
	Spark plug: DENSO Iridium IW... or NGK BR ... EG	12.4	
	Original battery must be used, FIAMM-GS type FG 20651 or FG 20722 or FGHL 20722 (as soon as available from ROTAX	12.5	
	Spark plug cap must be marked with "NGK TB05EMA".	12.6	
FUEL PUMP:	The original diaphragm pump (out of plastics with grey or black colour) must fitted by means of the two original silent blocks to the chassis of the kart.	14.1	
	The highest point of the fuel pump may not be higher than 100 mm above the main tube of the chassis.	14.2	
FUEL FILTER:	The original fuel filter (ROTAX part no. 274 160) only is allowed to be fitted between the fuel tank and the fuel pump. Any non original in line fuel filter has to be fitted between the fuel pump and the carburettor.	15.1	
RADIATOR:	Single aluminium radiator.	16.1	
	Name "ROTAX" is stamped in the top of the radiator.	16.2	
	Cooling area: Height = 284 mm, width = 202 mm	16.3	
	Thickness of radiator = 32 mm	16.4	
	The radiator must be fitted on the left side of the	16.5	

	<p>kart beside the seat.</p> <p>The highest point of the radiator with cap may not be higher than 400 mm above the main tube of the kart chassis.</p> <p>No additional cooling device is allowed.</p> <p>All other means of air flow control through the radiator are prohibited.</p>	<p>16.6</p> <p>16.7</p> <p>16.8</p>	
RADIATOR COOLANT	As glycol coolants are not permitted, distilled water without any additives has to be used.	17.1	
CLUTCH:	<p>Centrifugal clutch in oil bath, engagement r.p.m. maximum at 4.000 r.p.m.</p> <p>That means, that the kart (without driver) must start to move latest at an engine speed of maximum 4.000 r.p.m.</p>	18.1	
INTAKE SILENCER:	<p>Intake silencer with integrated, washable air filter.</p> <p>The intake silencer case is marked on the inside with the ROTAX part no. 225 012.</p> <p>The intake silencer cover is marked on the inside with the ROTAX part no. 225 022.</p> <p>The air filter is marked with the ROTAX part no. 225 052.</p> <p>The air filter must be assembled between the intake silencer case and intake silencer cover that the hole area of the intake silencer case is covered.</p>	<p>19.1</p> <p>19.2</p> <p>19.3</p> <p>19.4</p>	
EXHAUST SYSTEM:	<p>Must be as supplied by ROTAX and cannot be modified except for the replacement of the silencer absorption material and the use of threaded fasteners in place of the rivets for securing the silencer end cap.</p> <p>Standard exhaust socket must be used.</p> <p>The expansion chamber and silencer supplied with the engine may not be modified, except for the addition of extra elements to further reduce noise levels.</p>	<p>20.1</p> <p>20.2</p> <p>20.3</p>	
NOISE EMISSIONS:	Noise isolating mat (illustration 7, pos. 3) has to be replaced by a original ROTAX spare part, if	21.1	

the noise emission is exceeding 94 dB (A).

Noise emission measuring procedure:

- The measuring place has to be at section of the track where the engine is operated under full load and at a rpm range of 11.000 to 12.000 rpm.
- The microphone has to be installed 1 meter above the level of the track in a rectangular angle to the track.
- The distance between the microphone and the kart on the ideal line on the track has to be 7,5 meters.
- The kart has to be operated under full load at the ideal line on the track.

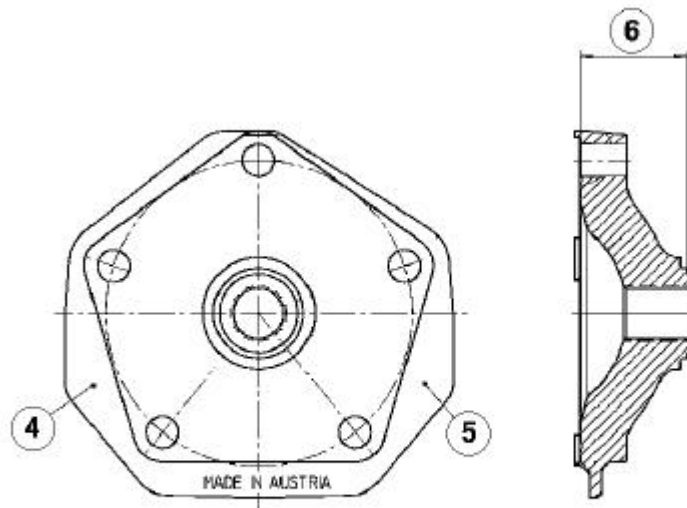

Illustration 1

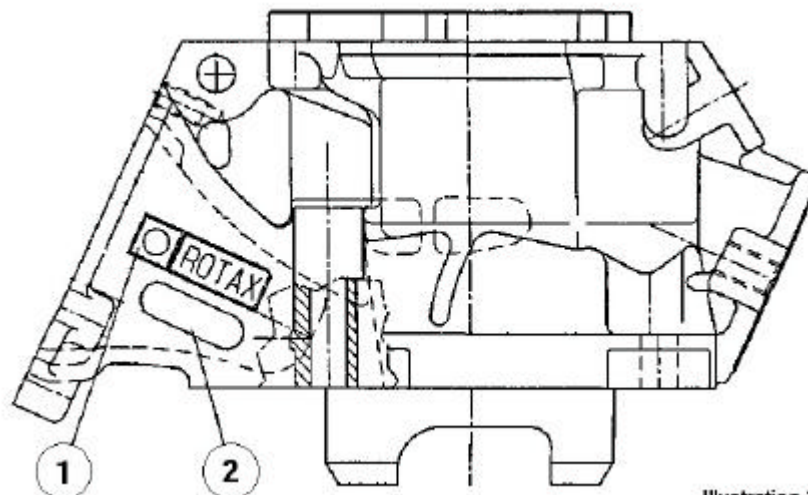

Illustration 2

